

## GAT Access 6100 Access Control Terminal

### Application

The GAT Access 6100 is a stylish terminal for access control in leisure facilities such as swimming pools, spas and gyms. Identification at the terminal is by contact-free RFID data carrier (Radio Frequency Identification).

Information display for user guidance is realised via a graphical monochrome display (LCD). The different versions (see order information) give technological flexibility.



### Function description

The GAT Access 6100 reads contact-free data carriers and checks and grants authorisations. The user holds the data carrier over the round scan field and selects the required service via the acknowledge key. The integrated 4-segment LED display, monochrome LCD display and acoustic signal indicate authorisation.

Further functions:

- Activation of turnstiles, doors etc. via relay output
- Feedback input
- User guidance via monochrome display (LCD), 4-segment LED display, illuminated round scan field and beeper
- Secure data transmission between reader and data carrier
- RFID frequency 13.56 MHz
- Reading of LEGIC®, MIFARE™ standard and ISO 15693 data carriers (depending on the device type)
- Opening of housing only possible with special tool
- Plug & Play installation

### Order information

Description	Part No.
<b>GAT Access 6100 B</b> Access control terminal with monochrome display (LCD) and contact-free reader for LEGIC® data carriers	651681
<b>GAT Access 6100 F</b> Access control terminal with monochrome display (LCD) and contact-free reader for MIFARE™ data carriers	776487
<b>GAT Access 6100 ISO</b> Access control terminal with monochrome display (LCD) and contact-free reader for ISO 15693 data carriers	651782

### Accessories

Description	Part No.
<b>GAT Access 6100 Manual</b> Operating and configuration instructions, English	332727
<b>GAT Reader WK</b> Tool to open the reader housing	581683

## Technical data

Nominal voltage:	12/24 VDC (SELV - safety extra-low voltage)
Permitted input voltage:	10 to 28 VDC
Aver. power consumption:	3 W
Data storage:	Internal EEPROM memory for configuring and booking memory, data preservation min. 10 years
Internal clock:	Data preservation approx. 12 h (Gold-Cap)
Reader type:	See order information
Frequency of reading field:	13.56 MHz
Control elements:	- 4 function keys - RFID reader
Display elements:	- Full graphics monochrome display (LCD) with white LED background lighting, resolution 128 x 64 pixels, visible area 50 x 25 mm - RFID reader (illuminated) - Acoustic signal - 4-segment LED display with different colours
Host interface:	Ethernet 10/100 MBit/s

Signal input:	1 x optocoupler (configurable) - Input voltage: 0 to 30 VDC - $U_{Low} < 2$ VDC, $U_{High} > 6$ VDC - Input current: 4.5 mA
Signal output:	1 x relay (configurable NO/NC) - Switching voltage: max. 30 VAC/DC - Continuous current: max. 2 A - Switching power: max. 60 VA
Connection terminals:	0.5 to 1.5 mm <sup>2</sup>
Housing material:	- Upper part: plastic PMMA - Back part: plastic PC-ABS
Dimensions:	93 x 107 x 33 mm
Permitted ambient temperature:	-10 to +50 °C
Storage temperature:	-20 to +70 °C
Relative humidity:	20 to 80%, non-condensing
Protection type:	IP 54
Protection class:	III
Weight:	0.2 kg
Environment class based on VDS 2110:	II (conditions in indoor areas)

## Dimensions

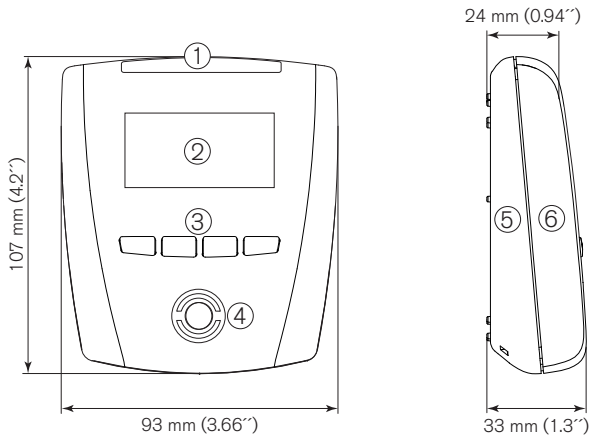

1. 4-segment LED display
2. Monochrome display (LCD)
3. Function keys
4. Illuminated, round scan field
5. Device back part
6. Device upper part

## Typical application

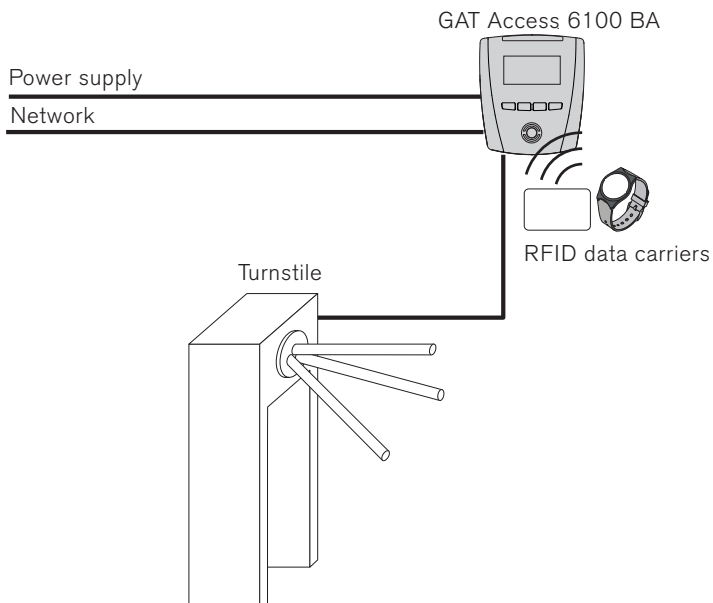

## Mounting and installation instructions

The device back part is secured by screws to a flat background (e.g. concrete wall). When fixing to an uneven background the device back part must not be distorted as this will prevent correct connection of the upper part. Recommended mounting height: top edge of device 1.3 m. Use the drilling template which is attached to the device.

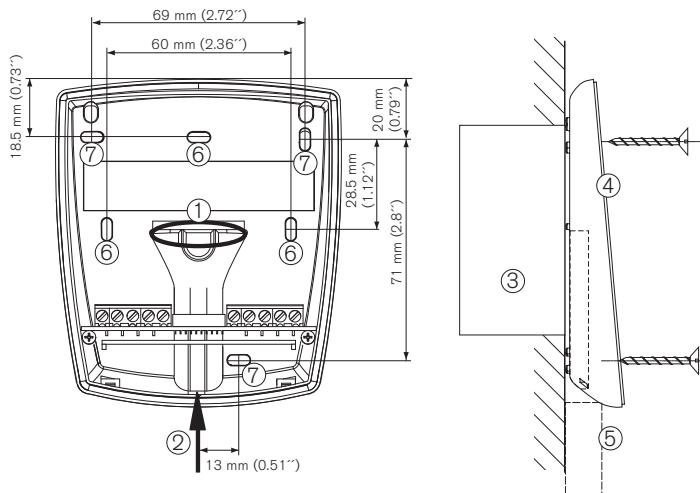

### Wall mounting

Cables can be flush (1) or surface-mounted (2).

When surface mounting please check whether the cables can still be inserted once the device back part has been mounted, otherwise run the cables through the cable lead-ins prior to securing.

1. Flush-mounted cable
2. Surface-mounted cable
3. Back box
4. Device back part
5. Cable conduit for surface cable connection

### Mounting the device upper part

Once the connection cables are terminated, the device back part and upper part are connected together via a connection cable (already connected in the upper part) and the two parts are fixed together.

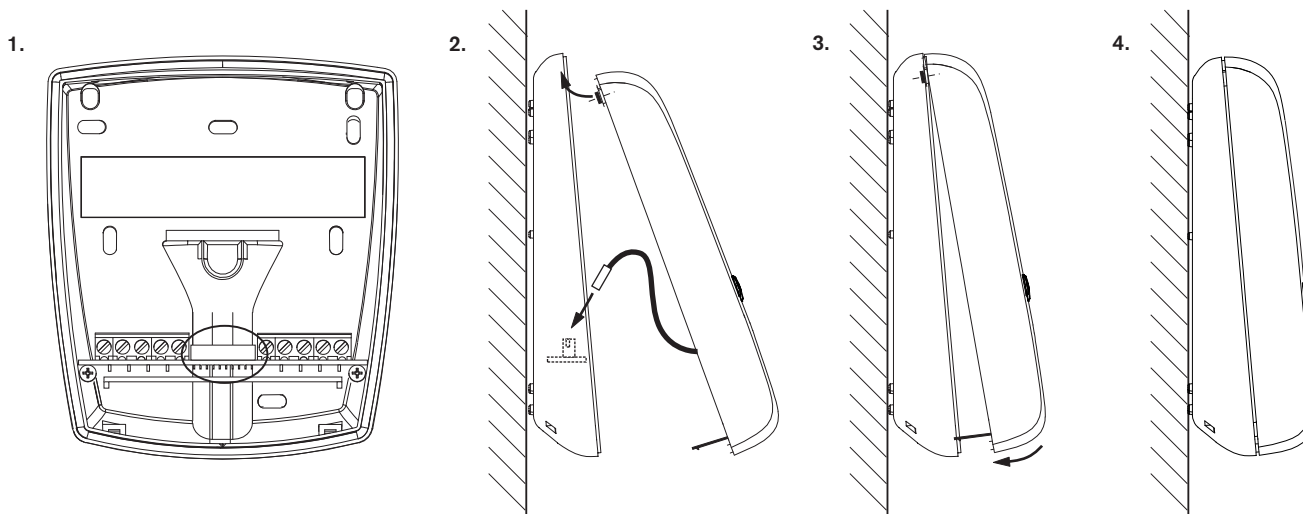

Notes:

1. Check the socket in the device back part (circled in figure 1). Dirt, dust and humidity must be removed so that a good contact of the connection cable is guaranteed. No aggressive detergent may be used. Please do not damage socket contacts.

**Attention:** Cleaning only in powerless state.

2. Plug in the connection cable into the socket in the device back part (consider alignment) and clip the top of the device upper part into the device back part.

3. Swing down the device upper part until it clicks.
4. The device can only be opened with the supplied special tool! With this the two catches on the bottom of the device can be unlocked in succession.

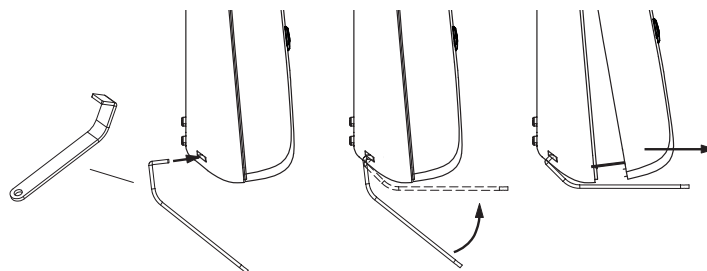

## Electrical connections

### TCP/IP with external power supply

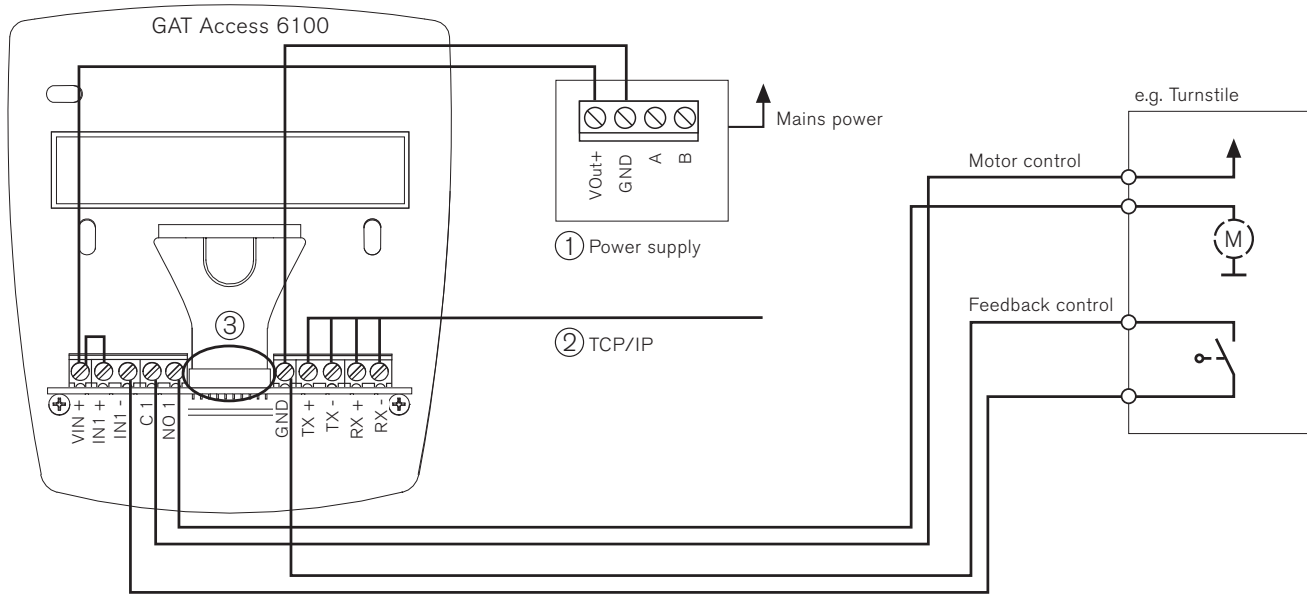

#### Network

Ethernet, Connection via screw terminals.

#### Power supply

DC supply (see technical data), e.g. via GANTNER GAT Power Supply SP014/1. The power input is protected against reverse-polarity.

#### Recommended cables:

Ethernet: min. CAT 5 (STP) for 100 MBit

#### Wire colours

	Ethernet 10/100 MBit	
	568A	568B
TX +	green/white	orange/white
TX -	green	orange
RX +	orange/white	green/white
RX -	orange	green

#### Connection to the device upper part

**Attention:** The socket (3) for the connection cable between the device back part and the device upper part must be clean in order to guarantee a good contact.

#### Relay output



For activation of devices like turnstiles etc.. The relay contact is of type NO (maker contact). Please observe the max. permitted switching voltages and currents (see technical data).

Depending on the connected installation (e.g. turnstile) an additional free-wheeling diode may be necessary, which is used to limit the switch-on current. Please read the documentation of the connected installation.

#### Optocoupler input

Input for status acquisition. For using the input a supply voltage must be applied. This voltage can be taken from the terminal's supply or from an external power source. Please observe the max. permitted input voltages and currents (see technical data).

#### Safety instructions

-  - This device must be installed by qualified personnel only.
- The applicable safety and accident prevention regulations must be observed.
- Safety devices must not be removed.
- Please observe the technical data of the device specified on the data sheet.
-  - The device must be disconnected from the power supply prior to installation, assembly or dismantling.